

*Finisar*<sup>®</sup>

*Fiber Optic Solutions  
for High-Speed Networks*

# **New High Speed I/O Options for Embedded System Interconnectors**

Jan Meise, Director of Strategic Marketing  
[jan.meise@finisar.com](mailto:jan.meise@finisar.com)

**ATCA Summit Oct 28, 2009**

**Santa Clara**

# Finisar Overview

- ◆ **A market leader**
  - Broad product offering of fiber optic transceivers/transponders and components
- ◆ **Focused on high-speed data communications**
  - Local Area Networks (LANs)/Storage Networks (SANs)
  - Metropolitan Networks (Metro/Telecom/CATV/FTTx)
  - High-speed serial and parallel protocols
- ◆ **Vertically integrated business model**
  - VCSELs for LAN/SAN
  - FP/DFBs for Metro/Telecom
  - Passive components
  - Optical packaging
  - Integrated circuit design
  - Internal off-shore manufacturing capability
- ◆ **Headquarters in Sunnyvale, CA**
  - \$500M+ annual revenue run rate
  - 5000+ employees worldwide
  - R&D and manufacturing locations in four continents

## SAN/LAN Transceivers



## Metro/Telecom/CATV/FTTx



# Embedded Design Challenge

- ◆ 1 GbE pipes are starting to fill up with high resolution video entering new markets such as:
  - Industrial/Automation
  - Military
- ◆ Aggregation of 1 GbE pipes leading to a need for 10 GbE pipes
- ◆ Embedded form factors are real-estate challenged
  - Customers used to RJ-45 jack size

***So how do we get to 10 GbE?***



# 10 GbE Option 1: 10GBase-T

- ◆ Next generation RJ-45 copper challenges
  - Availability of robust interoperability
    - Ecosystem still in prototyping/development stage
  - Power
    - Latest revision of PHYs consume 5-6 Watts
    - Promise of 4 Watts PHYs in next generation chip geometries
  - Need for new cat6a cables
  - Cost
    - No market volume yet

*...But it's RJ-45*



# 10 GbE Option 2: Optics Transceiver

- ◆ Most 10 GbE links shipping today based on optics transceivers
  - XFP and SFP+ are most common optical interfaces in PCI-e based Network Interface Card (NIC) designs and new switch designs
  - Allowing distances from meters to >100kms
  - Lower power than 10GBase-T
- ◆ But...
  - Optics is perceived as expensive
  - End users afraid of handling Optics



# 10 GbE Option 3: Active Optical Cables (AOC)

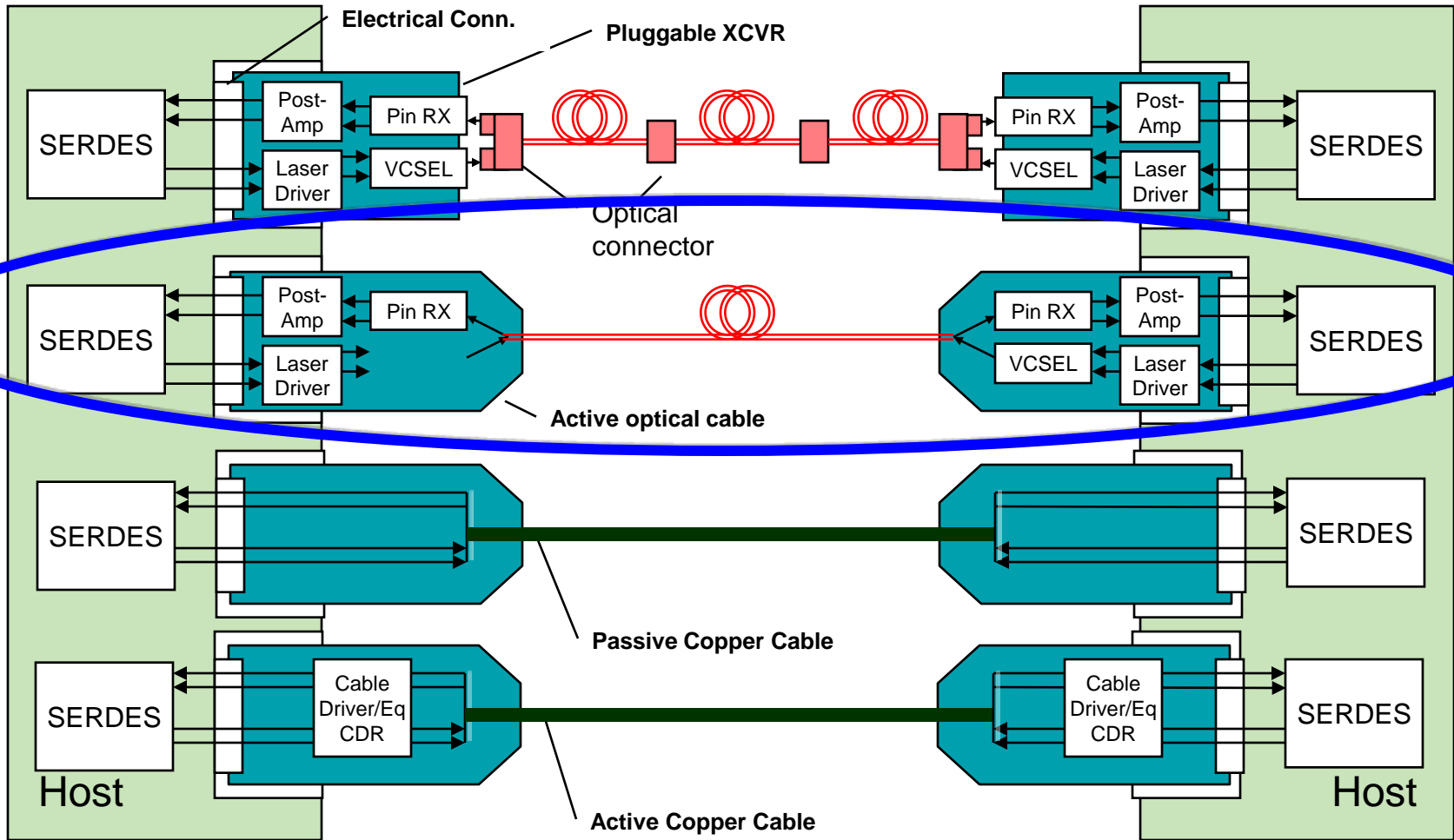

## Comparison of Cable Types and Optical Transceivers

# Introducing Active Optical Cables

- ◆ Advantages to Option 1: 10GBase-T
  - Saves 4-5W of power on each end
  - No challenge with EMI
  - Utilizes 10G SERDES outputs of ASSPs/ASICs/FPGAs with no need for separate PHY saving additional space
- ◆ Advantages to Option 2: Optical Transceivers
  - No optical connector cleanliness issues
  - Eliminate open optical specifications of transceivers driven by longer reach considerations
    - Only electrical amplitude and jitter specs
  - Vendor can choose best optical components, media for lowest cost
- ◆ Disadvantages
  - Not RJ-45
  - Unsuitable for structured wiring

# SERDES PHY Integration Driving Embedded Designs

- ◆ Driving single chip protocol/physical layer ecosystems
  - MAC/PHY for LOM
  - 10G serial Switch fabrics for ATCA backplane and serial I/O
  - High speed I/Os in FPGAs

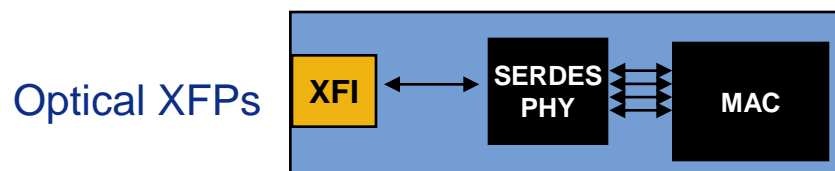
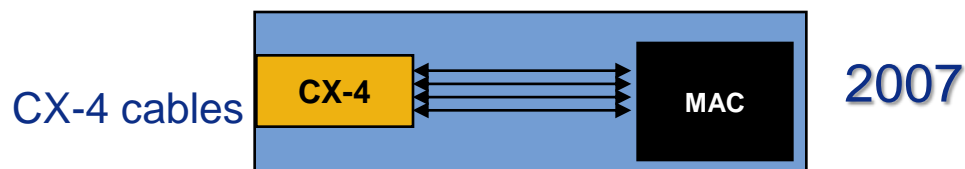

Single Chip MAC/PHY combo chips leading to 10 GbE LOM adoption

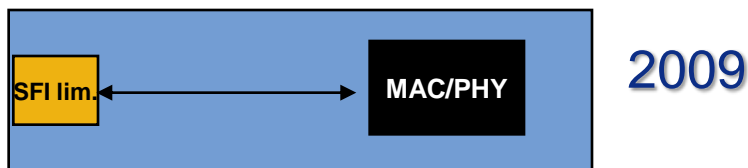

**Lowest power, Lowest cost, Lowest latency**



## Driving Active Cables Into Ethernet (SFF-8461)

- ◆ Reutilizes SFI limiting electrical spec
  - As standardized in SFF-8431 (10GBase-SR)
- ◆ Limiting interface (does not require external PHY on host)
  - Allows easier integration of SERDES functions into ASICs
  - Saves power on host, saves cost
  - Is the lowest electrical interface denominator of any host system design
- ◆ Allows distances of ~5-10m with active copper depending on implementation, 30m on active optical cables using POF and over 100m-GOF
- ◆ In the Datacenter
  - Good solution for short runs
  - Low cost for top-of-rack to server application

# Introducing Laserwire

- ◆ The first serial active optical cable addressing embedded applications
  - Small size
  - Low power



  
Laserwire™

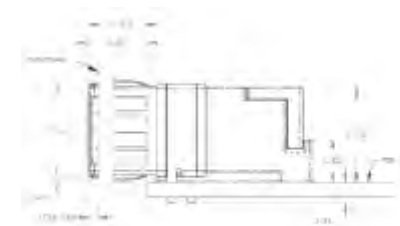

22.8mm length

# Laserwire Demonstrations

LED: **Green**

Far-end of cable  
is plugged in

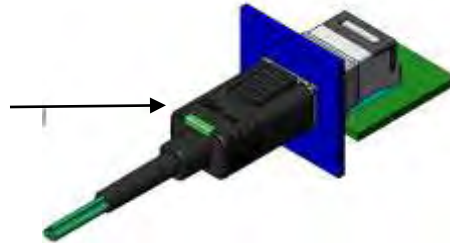

LED: **Red**

Far-end of cable  
not plugged in

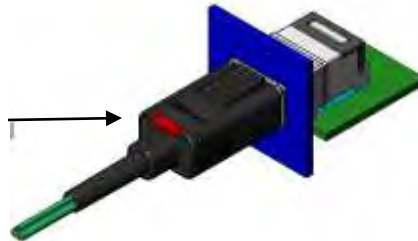

**Simplifies installation in high-count cable environments**

# Adapters for Other 10 GbE Form Factors

**Connectivity to legacy ports through  
SFP+ and XFP adapters**



**SFP+ adapter**



**XFP adapter**



# Supercomputing Laserwire Demonstration

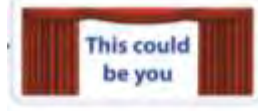

# Summary

- ◆ Maybe the future is not quite as bright, but →
- ◆ Active Optical Cables to drive 10G data rates into embedded systems
  - Low power
  - Small size
  - Connectivity to legacy ports (SFP+/XFP)
  - Low cost

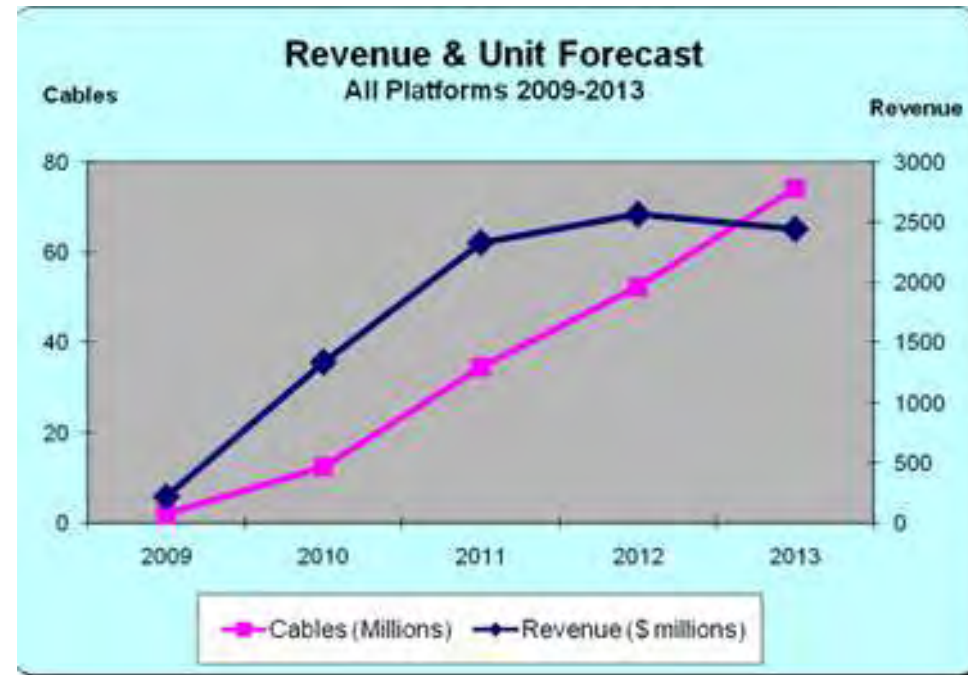

Active Optical Cable forecast from  
Information Gatekeepers